

INTERNAL SEAL FOR

HydraLock

SMALL-DIAMETER PIPE



Installation Procedure

2022
REVISION

Components & Functions

1. STAINLESS STEEL SLEEVE

The steel sleeve is manufactured from 316L stainless steel and provides uniform transfer of pressure distributed by the inflatable packer to the EPDM rubber gasket. The stainless steel sleeve is rolled to accommodate the required EPDM rubber gasket and designed for expanding to the inside diameter of the host pipe.

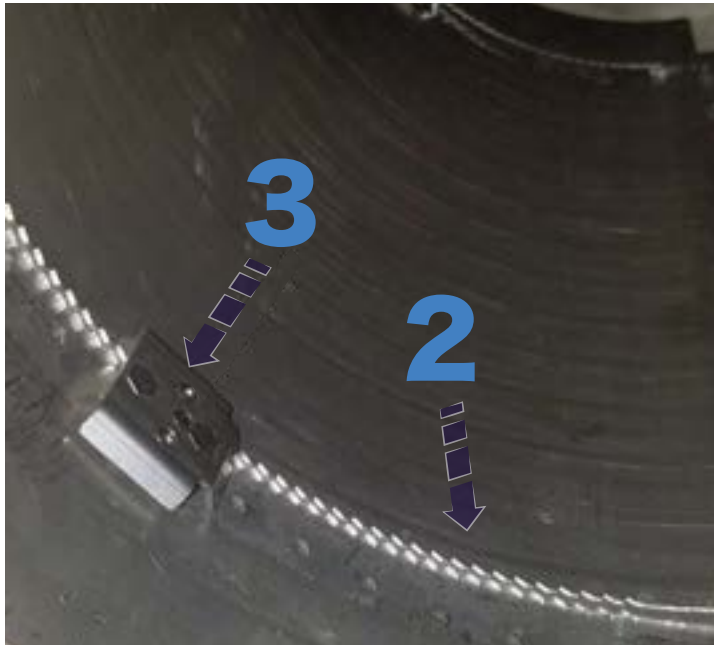

2. LOCKING CHANNEL

The steel sleeve is fabricated with locking channels which provide incremental travel and a travel guide for the locking device. The toothed channels are located on each end of the sleeve.

3. LOCKING DEVICE

The locking mechanism keeps the steel sleeve expanded after pressure is relieved. The stainless steel locking mechanism travels along the toothed channel and locks in place once pressure from the packer or pneumatic bladder is relieved.

4. EXPANDABLE HYDROPHILIC BAND

The hydrophilic O-rings expand upon contact with water, ensuring a watertight seal.



Installation Procedure

TYPES OF PIPES TO BE REPAIRED

HydraLock is suitable for repair all common types of pipe:

- Vitrified Clay Pipes
- Concrete Pipes
- PVC, HDPE and Similar Plastic
- Glass Reinforced Plastic Piping
- Steel, Cast Iron, Ductile Iron Piping

MATERIALS OF CONSTRUCTION

The HydraLock sleeve is made of **316L stainless steel** and suitable for use in:

- Municipal Wastewater Systems
- Industrial Wastewater
- Storm Water

The **EPDM gasket** is suitable for municipal wastewater, storm water, and many industrial systems. The EPDM has a (Shore A) Durometer of 40 and has excellent resistance to weathering, aging, and ozone degradation. EPDM is compatible with many polar substances such as ammonia, sulfur dioxide, hydrogen sulfide, and ethanol.

EPDM is not compatible with solvents, ketones, methane and hydrocarbon liquids.

For applications in which the EPDM may not be suitable, nitrile-butadiene rubber may be furnished. Consult with HydraTech Engineered Products LLC for proper selection of the rubber material.



RESTRICTIONS & LIMITATIONS

The following restrictions may limit the HydraLock from being used:

- Joints or Defects Near Bends or Fittings
- Defects Near Service Connections (Sockets, Branches)
- Pipes With Significant Joint Misalignment

TYPES OF PIPE DAMAGES

- Leaking joints in pressurized and gravity flow piping
- Leaks (ground-water infiltration & exfiltration)
- Sealing over unused off-takes or laterals
- Defects/concrete spalling in concrete piping
- Prevention of root penetration

LENGTH OF DAMAGE

The HydraLock seal has an overall length of 15.75” for all pipe diameters. The distance between the two hydrophilic O-rings allows for 9” of coverage for the repair.

SERVICE LIFE

When used in applications that are chemically compatible with stainless steel and EPDM construction, the HydraLock seal is capable of providing a reliable and long-lasting repair. A service life of 20 years minimum to more than 50 years can be expected for these applications, although the flow velocity, abrasiveness of the flow, temperature, etc. should also be considered.

Step By Step Installation

The following steps are to be performed outside the pipe or in the manhole.

Remove the HydraLock from the shipping box and removed the plastic wrap from the O-ring. Inspect the HydraLock assembly for any damage to the stainless steel sleeve, rubber seal, and O-rings.

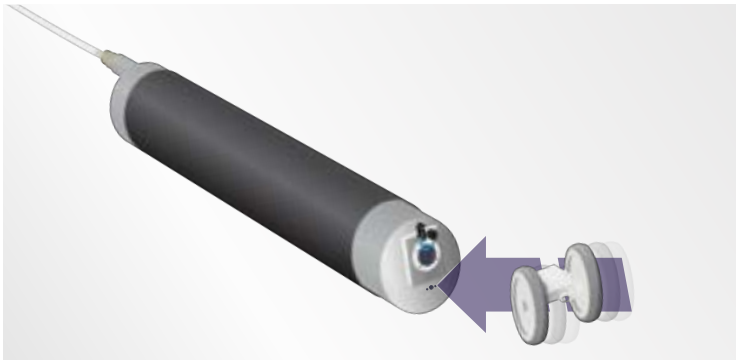

1. INSTALL PACKER'S FRONT WHEEL ASSEMBLY

Select packer suited for the diameter of the HydraLock. The packer diameter should allow the HydraLock assembly to easily slide over the packer's body. The packer should have a minimum length of 16 inches.

Select the correct set of wheels which align the center of the packer with the centerline of the pipe and install only the front wheel assembly.

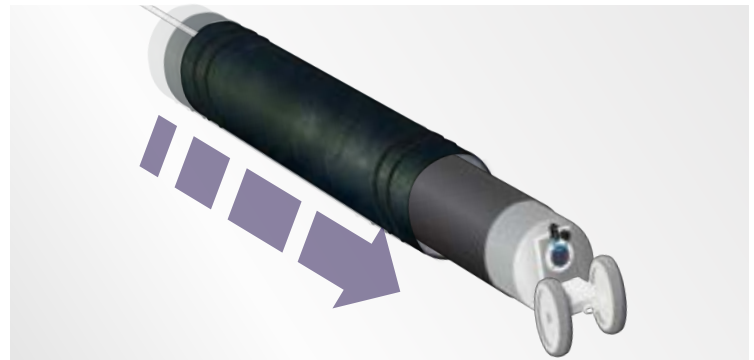

2. SLIDE HYDRALOCK OVER PACKER

Slide the HydraLock seal assembly over the packer. Align the edge of the HydraLock seal with the front end of the packer.

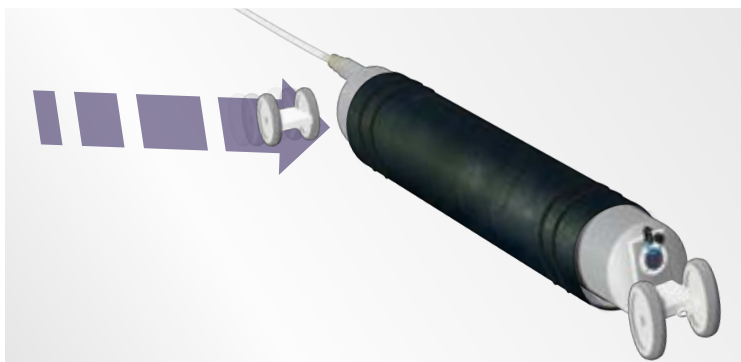

3. INSTALL PACKER'S REAR WHEEL ASSEMBLY

Once the HydraLock has been slid over the pack and is in place, install the rear packer's wheel assembly.

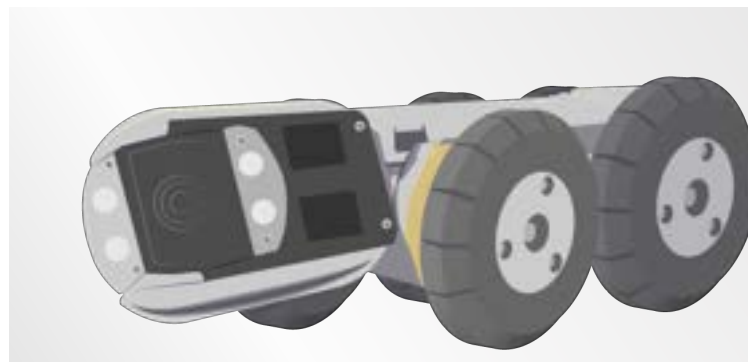

4. INSTALL CAMERA ON PACKER (OPTIONAL)

If using a camera, connect the camera to the front of the packer.

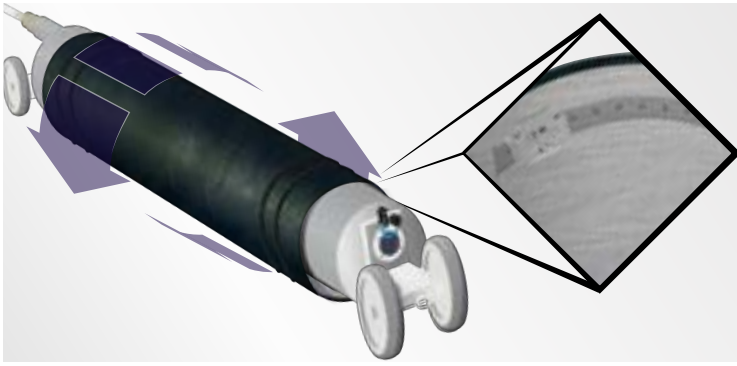

5. ENSURE THAT TOOTHED STRIP IS FACING UP

It is preferred that the locking mechanism and toothed strip are located at the crown of the pipe. If necessary, rotate or position the HydraLock seal such that the middle of the toothed strip is at the top of the pipe or in the 12 o'clock position.

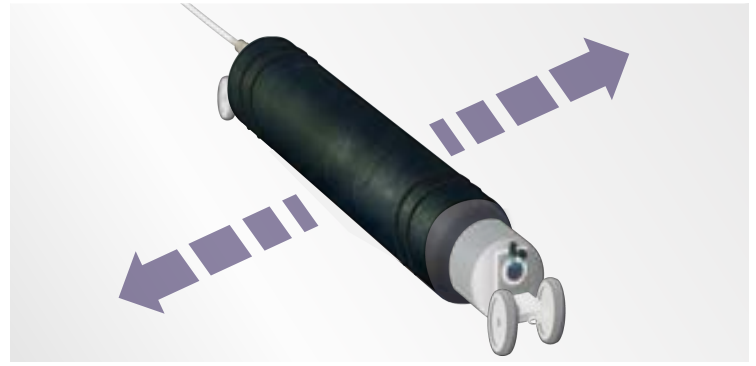

6. INFLATE PACKER TO IMMOBILIZE HYDRALOCK

With the HydraLock seal aligned with the front edge of the packer and the toothed strip at the top of the packer, connect the air supply and slowly inflate the packer to firmly hold the HydraLock seal in place without expanding the stainless steel sleeve of the HydraLock.



7. ALIGN HYDRALOCK WITH REPAIR LOCATION

Maintain (air) pressure while maneuvering the HydraLock assembly through the pipe to the repair location. Align the center of the HydraLock assembly over the pipe defect. The positioning may be accomplished by sight, camera image, or a distance counter or laser.

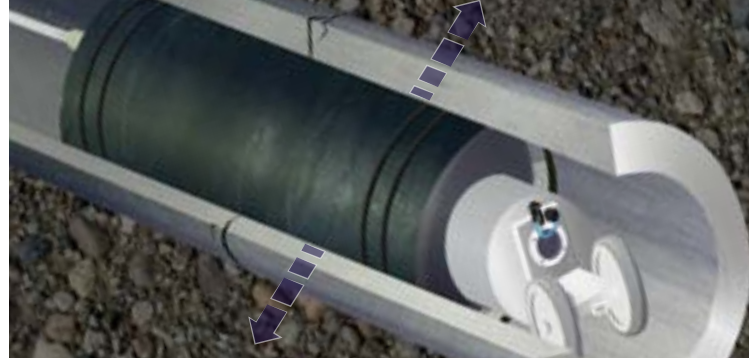

8. EXPAND PACKER

Once the HydraLock is positioned over joint or defect, inflate the packer to a final pressure of 80 psi. Hold and maintain the packer pressure for 10 min. Release the packer pressure and deflate to the minimum diameter and remove packer from the pipe.

